

User's Manual



Electromagnetic Flow Meter

CONTENTS

1.SUMMARY.....	1
2.WORKING PRINCIPLES.....	1
3.PRODUCT CLASSIFICATION.....	2
4.TECHNICAL SPECIFICATON.....	3
5.APPEARANCE AND INSTALLATION	4
6.CONVERTER OPERATION MENU AND PARAMETER SETUP.....	6
7.INSTALLATION.....	14
8.WIRING.....	16
9.SELF-DIAGNOSTICS AND TROUBLESHOOTING	2 2
10.PACKAGING.....	2 3
11.TRANSPORTATION AND STORAGE	2 3
12.OPERATION.....	2 3

1. SUMMARY

1.1 Features

● Measurement is not affected by the variation of flow density, viscosity, temperature, pressure and conductivity. High accuracy measurement is guaranteed according to the linear measurement principle.

● No obstacle in the pipe, no pressure-loss and lower requirement for straight pipeline.

● DN 6 to DN2000 covers a wide range of pipe size. A variety of liners and electrodes are available to satisfy different flow characteristic.

● Programmable low frequency square wave field excitation, improving measurement stability and reducing power consumption.

● Implementing 16 bits MCU, providing high integration and accuracy; Full-digital processing, high noise resistance and reliable measurement; Flow measurement range up to 1500:1.

● High definition LCD display with backlight.

● RS485 or RS232 interface supports digital communication.

● Intelligent empty pipe detection and electrodes resistance measurement diagnosing empty pipe and electrodes contamination accurately.

● SMD component and surface mount technology (SMT) are implemented to improve the reliability.

1.2 Main Applications

WELTER electromagnetic flowmeter can be used to measure the volume flow of conductive fluid in a closed pipeline. It is widely applied in the flow measurement and control in the fields of chemical and petroleum industry, metallurgy industry, water and waste water, agriculture and irrigation, paper making, food and beverage industry and pharmaceutical industry.

1.3 Ambient Conditions

Ambient temperature:

sensor: -25℃ to + 60℃; converter: -25℃ to + 60℃.

Relative humidity: 5% to 90%;

1.4 Working Conditions

Maximum fluid temperature:

Compact type: 60℃

Remote type: Teflon 150℃

Neoprene 80℃; 120℃

Polyurethane 70℃

Fluid conductivity: $\geq 5\mu\text{S}/\text{cm}$

2. WORKING PRINCIPLES

2.1 Measuring Principles

The measuring principle of electromagnetic flowmeter is based on the electromagnetic induction law of Farady. The sensor is mainly composed of measuring tube with isolate lining, a pair of electrodes installed by penetration of the measuring tube wall, a pair of coils and iron core to produce working magnetic

field. When the conductive fluid flows through the measuring tube of the sensor, the voltage signal in direct proportion to the average flow velocity of the fluid will be induced on the electrodes. The signal is amplified and treated by the transmitter to realize various display functions.

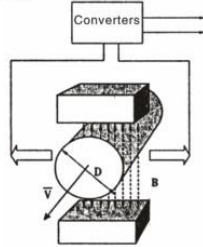

FIG. 1 : The electromagnetic flowmeter Working principle of the

2.2 Converter Circuit Schematic

The converters supplies a stable exciting current to the coil in the sensor of electromagnetic flowmeters to get B constant and amplifies the electromotive force and convert it into standard signals of current or frequency so that the signals can be used for displaying, controlling and processing. The schematic of converter circuit is shown in Fig. 2.

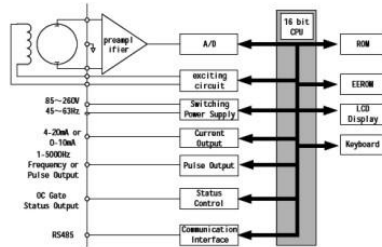

Fig. 2 Schematic of converter circuit

3. PRODUCT CLASSIFICATION

3.1 Product components

Electromagnetic flowmeter is composed of sensor and converter. The remote-type also needs a special double-layer shielded cable to connect the converter and the sensor.

3.2 Product models

WELTER electromagnetic flowmeter has two forms: compact-type and remote-type. There are seven kinds of electrode materials and four kinds of lining Materials available for sensor.

Materials available for sensor.

4. TECHNICAL SPECIFICATION

4.1 The flowmeter is compliant to Standard "JB/T 9248-1999 Electromagnetic Flow Meter" .

4.2 Maximum flow speed: 15m/s

4.3 DN size: 3, 6, 10, 15, 20, 25, 32, 40, 50, 65, 80, 100, 150, 200, 250, 300, 350, 400, 450, 500, 600, 700, 800, 900, 1000, 1200, 1400, 1600, 1800, 2000

4.4 Accuracy: 0.5%, 0.2%

4.5 Nominal Pressure: 4.0MPa(DN0-150)
1.6MPa(DN200-600)
1.0MPa(DN700-1200)
0.6MPa(DN400-2000)
Or other specified by order

4.6 Materials

Electrode Forms and Materials:

Electrode design has four forms: standard form, scraper form, detachable form and grounding electrode.

Electrode material is selectable from stainless steel containing Mo, stainless steel coated with carbonized tungsten, Hastelloy B, Hastelloy C, Titanium, Tantalum and platinum-iridium alloy.

Flange material: carbon steel

Grounding ring: stainless steel

Inlet protection ring: carbon steel, stainless steel

4.7 Enclosure

Ip65:

IP68: only available for remote-type sensor with neoprene or polyurethane liner, not including flameproof model.

4.8 Flameproof Standard

DN15-DN600 compact-type: md II Bt4

DN15-DN1600 remote-type: sensor and converter both installed in dangerous area: md II BT4.

DN15-DN1600 remote-type: sensor installed in dangerous area and converter installed in safe area: md II BT4

4.9 Connection Cable

Special cable is needed to connect the sensor and the converter for remote-type flowmeter.

The cable length should not exceed 100 meters. A 10-meter cable is supplied free of charge and the rest is to be ordered.

4.10 General Specification of Converter

● Power supply: AC 85-265V, 45-63Hz, ≤20W; DC 11-40V

● Converter display and operation: four keys are available to set all parameters. External handheld or PC can be used to do the configuration. High resolution LCD display with backlight, empty pipe detection and self-diagnostic function are equipped in the converter.

●Digital communication: RS485, RS232, MODBUS, REMOTE

●Output Signals:

- Current output: fully-isolated, 4-20mA/0-10mA

load resistance: 0-10mA: 0-1.5KΩ; 4-20mA: 0-750Ω.

-Frequency output: bidirectional flow output. Frequency output is proportional to the flow percentage of the full range. The converter provides fully isolated transistor open collector frequency output ranged from 1 to 5000 Hz. The external DC power supply should not exceed 35V and maximum collector current is 250mA.

- Pulse output: bidirectional flow output. The converter can output up to 5000cp/s pulse series, which is dedicated to external totalization. Pulse factor is defined as volume or mass per pulse. It can be set to 0.001L/p, 0.01L/p, 0.1L/p, 1L/p, 2L/p, 5L/p, 10L/p, 100L/p, 1m3/p, 10 m3/p, 100 m3/p or 1000 m3/p. Pulse width is selectable from auto, 10ms, 20ms, 50ms, 100ms, 150ms, 200ms, 250ms, 300ms, 350ms and 400ms. Photo-coupler isolated transistor open collector circuit is used for pulse output. The external DC power supply should not exceed 35V and maximum collector current is 250mA.

- Flow direction indication: The converter is capable of measuring both forward and reverse flow and recognizing its direction. The converter outputs 0V low level for forward flow, while +12V high level for reverse flow.

- Alarm output: Two channels of photo-coupler isolated open collector circuit are used for alarm signal output. There are two alarm outputs: high limit alarm and low limit alarm. The external DC power supply should not exceed 35V and maximum collector current is 250mA.

- Damping constant: Damping time is selectable from 0.2 to 100s.

5. APPEARANCE AND INSTALLATION

Dimensions of Converter, shown as Fig 3.

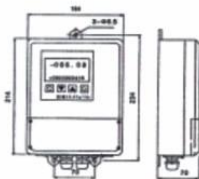

Fig3(a) Remote-type converter

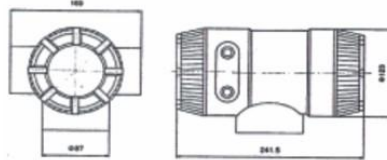
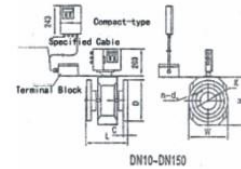

Fig3(b) Compact-type converter

Dimensions of sensor, shown as Fig 4.



Dimensions and weight

Nominal diameter DN	L	W	H	Refer to the weight kg	A shape sensor
20	200	140	154	12	9
25	200	140	156	14	11
32	200	168	166	15	12
40	200	176	172	16	13
50	200	176	191	17	14
65	250	214	200	25	22
80	250	214	218	29	26
100	250	230	242	31	28
125	250	281	277	36	33
150	300	281	302	41	38

Flange dimensions (standard: GB/T9119)

Nominal diameter DN	pressure 1.6MPa				pressure 4.0MPa			
	D	d ₁	d ₂	n b	D	d ₁	d ₂	n b
15	95	65	14	4 16	95	65	14	4 16
20	105	75	14	4 18	105	75	14	4 18
25	115	85	14	4 18	115	85	14	4 18
32	140	100	18	4 19	140	100	18	4 19
40	150	110	18	4 20	150	110	18	4 20
50	165	125	18	4 20	165	125	18	4 20
65	185	145	18	4 20	185	145	18	8 22
80	200	160	18	8 22	200	160	18	8 22
100	220	180	18	8 22	235	190	22	8 26
125	250	210	18	8 22	270	220	26	8 26
150	285	240	22	8 24	300	250	26	8 28

DN15-DN150, 1.6, 4.0 Mpa Sensors and a body shape

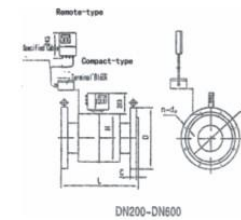

Dimensions and weight

Nominal diameter DN	L	H	Φ	Refer to the weight kg
250	450	412	50	
300	500	472	60	
350	500	522	145	
400	500	572	180	
450	550	626	215	
500	550	676	245	
600	600	776	335	

Flange dimensions (standard: GB/T9119)

Nominal diameter DN	pressure 1.6MPa				pressure 4.0MPa			
	D	d ₁	d ₂	n b	D	d ₁	d ₂	n b
200	340	295	22	12 26	340	295	22	8 24
250	405	355	26	12 28	395	350	22	12 26
300	460	410	26	12 32	445	400	22	12 28
350	520	470	26	16 35	505	460	22	16 30
400	580	525	26	16 38	565	515	26	16 32
450	640	585	30	20 42	615	565	26	20 35
500	715	650	30	20 46	670	620	26	20 48
600	840	770	36	20 52	780	725	30	20 42

DN200-DN600, 1.0, 1.6Mpa

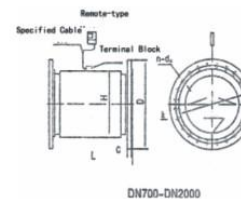

Dimensions and weight

Nominal diameter DN	L	H	Φ	Refer to the weight kg
800	800	966	545	
900	900	1076	655	
1000	1000	1200	810	
1200	1200	1406	875	
1400	1400	1632	1235	
1600	1600	1832	1555	
1800	1800	2036	2085	
2000	2000	2236	2610	

Flange dimensions (standard: GB/T9119)

Nominal diameter DN	pressure MPA	D				d			
		D	d ₁	d ₂	n b	D	d ₁	d ₂	n b
700	1.0	895	840	30	24	30			
		1015	950	33	24	32			
		1115	1050	33	28	34			
900	0.6	1230	1160	36	28	34			
700		860	810	26	24	26			
800		975	920	30	24	26			
900	0.6	1075	1020	30	24	26			
1000		1175	1120	30	28	26			
1200		1405	1340	33	32	28			
1400	0.6	1630	1560	36	36	32			
1600		1830	1760	36	40	34			
1800		2045	1970	39	44	36			
2000		2265	2180	42	48	38			

DN700-DN2000, 1.0, 1.6Mpa

Remark:

1. Nominal Pressure 4.0 MPa for DN10–150; Nominal Pressure 1.6 MPa for DN10–1000; Nominal Pressure 1.0 MPa for DN10–1600; Nominal Pressure 0.6 MPa for DN10–2000. Other special pressure level can be designed on demand.

2. The length L increases 6 mm if ground flange is equipped; The length L increases 6 mm if inlet protection flange is equipped; The length L increases 6 mm if liner protection flange is equipped.

6. CONVERTER OPERATION MENU AND PARAMETER SETTING

6.1 Keypad and Display

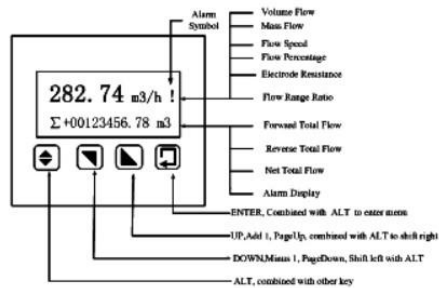

Fig.5(a) Remote-type key and display

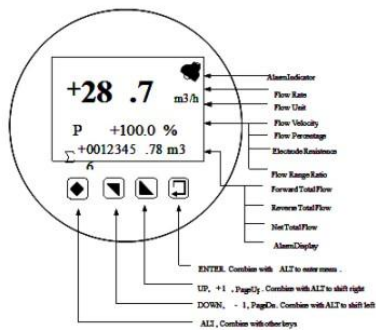

Fig.5(b) Compact-type key and display

6.2 Keypad Function

1. Automatic Measurement Mode

DOWN: Scroll bottom line display;
UP: Scroll top line display;

ALT + ENTER: Enter into setting mode;
ENTER: Return to measurement mode.

2. Parameter Setting Mode

DOWN: Subtract one from the digit at the cursor;

UP: Add one on the digit at the cursor

ALT + DOWN: Cursor shifts left

ALT + UP: Cursor shifts right

ENTER: Enter/exit submenu;

ENTER: Return to measurement mode if held for 2 seconds at

any location

Remarks:

(1) When using ALT key, hold ALT first and then press UP or DOWN.

(2) Under setting mode, the meter returns to measurement mode automatically if no key is pressed for 3 minutes.

(3) When adjusting flow zero, UP or DOWN key can be used to change the sign (+/-).

(4) When setting flow range, UP or DOWN key can be used to change flow unit.

6.3 Parameter Configuration and Operation Password

The setting parameters determine the operation status, calculation method and output mode of the flow meter. Properly setting meter parameter can make the meter work in best condition and higher accuracy of display and output can be obtained.

There are five levels of password, where level 0 – 3 are open for user and level 4 reserved for manufacturer. Level 1 to 2 passwords are changeable by higher level password-holder, e.g. Level-3 password.

Meter setting can be browsed by entering any level of password. However, higher level password is needed to change settings.

◆ Password Level-0 (default value 0521): fixed and browsing only;

◆ Password Level-1 (default value 7206): changeable and authorized to modify menu item 1 to 25;

◆ Password Level-2 (default value 3110): changeable and authorized to modify menu item 1 to 29;

◆ Password Level-3 (default value 2901): fixed and authorized to modify menu item 1 to 38;

◆ Password Level-4 (reserved): fixed and authorized to modify any menu item including resetting system.

Totalizer Reset Password (default value 36666): changeable in menu item 'Clr Tot. Key' and authorized to clear the three internal counter.

It is suggested that Level-3 password be held by manager or supervisor while

Level-0 to 2 passwords be kept by operator. The Level-3 password can also be used to change the password for totalizer resetting.

6.4 Table of Parameter Setting Menu

The converter setting menu consists of 45 items. Many of them are set up by manufacturer before shipping. It is not necessary to change them when applying. There are only a few of them to be set by user according to the application. The menu items are listed in the table below:

Item No.	Menu Display	Setting Method	Password Level	Value Range
1	Language	Option	1	English
2	Sensor Size	Option	1	3 – 3000mm
3	Flow Range	Modify	1	0 – 99999
4	Auto Rng Chg	Option	1	ON / OFF
5	Damping	Option	1	0 – 100 s
6	Flow Dir.	Option	1	Fwd/ Res
7	Flow Zero	Modify	1	+/-0.000
8	L.F. Cutoff	Modify	1	0 – 99%
9	Cutoff Enble	Option	1	ON / OFF
10	Rate-Of-Chng	Modify	1	0 – 30%
11	Limit Time	Modify	1	0 – 20 s
12	Total Unit	Option	1	0.0001L – 1 m3
13	Flow Density	Modify	1	0.0000 – 3.9999
14	Current Type	Option	1	4–20mA/0–10mA
15	Pulse Output	Option	1	Frq/ Pulse
16	Pulse Factor	Option	1	0.001L – 1 m3
17	Freq Max	Modify	1	1 – 5999 Hz
18	Comm Address	Modify	1	0 – 99
19	Baudrate	Option	1	600 – 14400
20	EmpPipe Det.	Option	1	ON / OFF
21	EmpPipe Alm	Modify	1	200.0 K Ω
22	Hi ALM Enble	Option	1	ON / OFF
23	Hi Alm Limit	Modify	1	000.0 – 199.9%
24	Lo Alm Enble	Option	1	ON / OFF
25	Lo Alm Limit	Modify	1	000.0 – 199.9%
26	RevMeas.Enbl	Option	1	ON/OFF
27	Sensor S/N	Modify	2	000000000000–999999999999
28	Sensor Fact.	Modify	2	0.0000 – 3.9999
29	Field Mode	Option	2	Mode 1,2,3
30	Multiplying	Modify	2	0.0000 – 3.9999
31	F. Total Set	Modify	3	0000000000 – 9999999999
32	R.Total Set	Modify	3	0000000000 – 9999999999
33	Input Contrl	Option	3	Disable/Stop Tot/Reset Tot
34	Clr Totalizr	Password	3	00000 – 59999

35	Clr Tot. Key	Modify	3	00000 – 59999
36	Date-y/m/d *	Modify	3	99/12/31
37	Time-h/m/s *	Modify	3	23/59/59
38	Password L1	Modify	3	0000 – 9999
39	Password L2	Modify	3	0000 – 9999
40	Password L3	Modify	3	0000 – 9999
41	Current Zero	Modify	4	0.0000 – 1.9999
42	Current Max	Modify	4	0.0000 – 3.9999
43	Meter Factor	Modify	4	0.0000 – 3.9999
44	Convtr S/N	Modify	4	0000000000–9999999999
45	Sys Reset	Password	4	

* Item No. 36 and 37 are optional and only effective for the converter with real clock and power failure recording function.

6.5 Parameter Setting Explanation

6.5.1 Sensor Size

The converter supports sensor diameter ranging from 3 to 3000mm, which can be chosen by pressing UP or DOWN key.

6.5.2 Flow Range

Flow range refers to the upper range value (URV) of flow rate. The URV is relative to flow percentage and output signal. At the analog output the amount of the measured values in the range 0 up to URV is displayed linear to the current range 4 to 20mA, at the frequency output to the frequency range 0 to the end frequency. The low flow cutoff and flow limit alarm relates to flow range as well. The maximum measurable flow rate, however, is not limited to the flow range as long as the flow speed does not exceed 15m/s.

In this menu item, user can also choose unit of flow rate. For volume flow, L/s, L/min, L/h, m3/s, m3/min and m3/h are available; while for mass flow, kg/s, kg/m, kg/h, t/s, t/m, t/h can be selected from. It is up to the habits and application requirements to pickup a proper unit.

6.5.3 Auto Rng Chg

The converter has a function called Auto-Range-Change that is usually used for control system with wide flow range variation. The primary flow range is the value given by menu item 'Flow Range'. The second flow range (lower range) is obtained by selecting range ratio 1:2, 1:4 or 1:8 of primary one.

Fig 6 illustrates how the flow range is changed automatically. To safely change range and avoid vibration of display and output, a 5% to 10% hysteresis is added at the change point.

6.5.4 Damping

Long damping constant can improve the stability of display and output and is

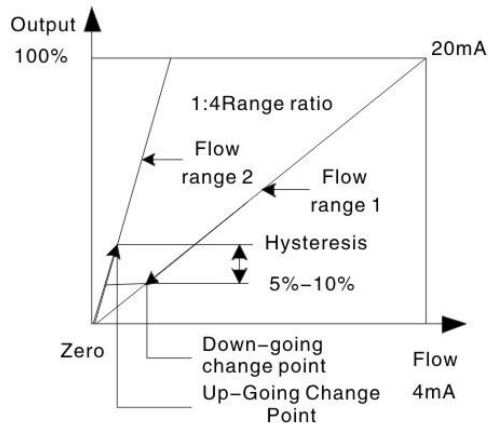

Fig. 6 Illustration of Auto-Range-Change

Suitable to flow control application; while short damping constant has short Response time and is suitable to the totalization of pulse flow. Damping time is selectable from 0.2s to 100s.

6.5.5 Flow Dir.

If the displayed direction sign is not agreed to the actual flow direction, change this item to the opposite option.

6.5.6 Flow Zero

To conduct zero adjustment, the fluid in the sensor pipe must be held still. The flow zero is displayed by flow speed and the unit is m/s. The display of flow zero is shown below:

FS=○○.○○○m/s
 ±○○○○○

On the LCD, the top line displays the measured zero point while the bottom line shows the adjustment value. If the FS is not equal to 00.000m/s, adjust the sign and value on bottom line until FS back to nil. Remind again: to adjust the flow zero, the sensor pipe must be filled and the fluid must be kept still. The flow zero adjustment value is an important constant of the meter and should be printed on the calibration sheet and label. The value should include the sign and amount by unit of m/s.

6.5.7 L.F. Cutoff and Cutoff Enable

Low flow cutoff is set in percentage relative to flow range. If Cutoff is enabled and flow is lower than the set value, the display of flow rate, speed and percentage

and signal outputs are forced to nil. If the item is disabled, no action is taken.

6.5.8 Rate-Of-Chng and Limit Time

'Rate-of-change' limit technique is used to eliminate application-related high electrical noise contained in the process flow signal.

To check electrical noise, two parameters are defined: 'Rate-of-change' limit and 'Control limit time'. If the sampled flow value exceeds the set rate-of-change limit value based on the averaged flow rate value up until the sampled time, the system will reject that sampled value and instead the averaged value including the rate-of-change limit value in place of the rejected sampled value will be output. However, if the limit-exceeding sampled value continues for the same flow direction for more than the preset control limit time, that data will be used as output signal. Fig 7 illustrates the effect of noise-suppressing by rate-of-change limit.

The value of rate-of-change limit can be set from 0 to 30% of flow range and limit time ranges from 0 to 20 seconds. If either of the two parameters is set to nil, the function is disabled.

The rate-of-change limit function is not suitable for short period measurement and flow meter calibration.

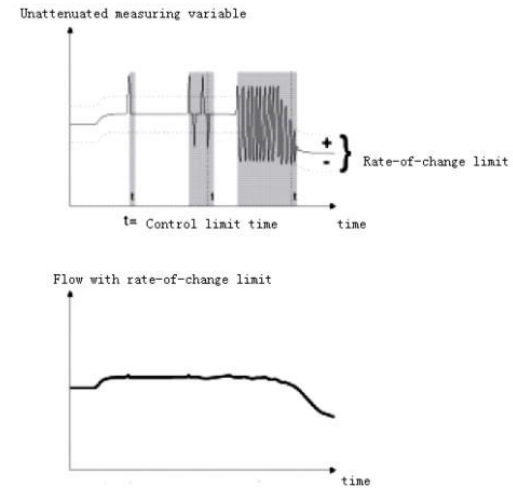

Fig.7 Example for the effect of rate-of-change limit

6.5.9 Total Unit

The converter has three 10-digit counters and the maximum counts are 999999999. The total flow unit can be L, m3, kg or t (metric ton) with a multiplying factor of 0.001, 0.01, 0.1, 1, 10, 100 or 1000.

6.5.10 Flow Density

The converter is capable of measuring mass flow if fluid density is set. The density can be set from 0.0001 to 3.9999 and the mass unit is determined automatically by flow unit. The density should be set to 1.0000 (default value) if not used. Otherwise, measurement data will be forced to nil.

6.5.11 Current Type

Current output type is selectable from 4–20mA to 0–10mA.

6.5.12 Pulse Output

Two types of pulse output are available to choose from: frequency output mode And pulse output mode. The meter outputs continuous square wave pulse under frequency mode, while pulse series under pulse mode. Frequency output is usually used for flow rate measurement and short period of time totalization. Pulse output can be connected to an external counter directly and is often used for long period of time totalization.

As mentioned hereinbefore, transistor open collector circuit is used for frequency and pulse output. Therefore, the external DC power supply and load are necessary. Pulse Factor

6.5.13 Pulse factor is defined as: volume or mass per pulse. It can be set to 0.001L/p, 0.01L/p, 0.1L/p, 1L/p, 2L/p, 5L/p, 10L/p, 100L/p, 1m3/p, 10 m3/p, 100 m3/p or 1000 m3/p. Pulse width is selectable from auto, 10ms, 20ms, 50ms, 100ms, 150ms, 200ms, 250ms, 300ms, 350ms and 400ms.

6.5.14 Freq Max

Frequency range corresponds to the upper range value of flow rate, or 100% of flow percentage in other word. Maximum frequency is selectable from 1 to 5999Hz.

6.5.15 Comm Address and Baudrate

Substation address is needed when using RS485 communication. The address can be set from 01 to 99. Baud rate is the transmission speed between main and sub station. It is selectable from 600, 1200, 2400, 4800, 9600, 14400bps. Remind: the baud rate must be the same as that of the main computer.

6.5.16 EmpPipe Det.

This item is used to enable or disable the empty–pipe detector. If enabled, the meter will force the display value, analog output and digital output to nil when the sensor pipe is not full.

6.5.17 EmpPipe Alm.

This item is to set the electrode alarm trip value. Constant current source method is employed to measure the resistance between two electrodes. The Variation of the resistance is checked by CPU and CPU recognizes if the pipe is empty or the electrodes are contaminated. The resistance is calculated as following:

$$R \approx \frac{1}{d \sigma}$$

Where, d = electrode radius
 σ = Fluid conductivity

The electrodes resistance is usually between 5 to 50k Ω . The variation of the resistance relates to the surface status of electrodes and variation of fluid characteristic. If the sensor is filled with fluid, abnormal resistance signal is detected and empty pipe alarm is output.

The electrode alarm trip value is determined based on the first–time measured electrode resistance. After the installation of the flowmeter, measure the resistance between the electrodes when the sensor pipe is filled. Record the resistance value and take it as a basis. Usually, set the trip value as 3 times of the original resistance recorded.

6.5.18 Hi ALM Enble

User can enable or disable the high limit alarm.

6.5.19 Hi Alm Limit

High alarm limit value is set in percentage of the upper range of flow rate. The parameter ranges from 0% to 199.9%. The meter outputs alarm signal when the flow percentage is higher than this value.

6.5.20 Lo Alm Enble

User can enable or disable the low limit alarm.

6.5.21 Lo Alm Limit

Low alarm limit value is set in percentage of the upper range of flow rate. The parameter ranges from 0% to 199.9%. The meter outputs alarm signal when the flow percentage is lower than this value.

6.5.22 Sensor S/N

Sensor serial number records the information of the sensor equipped with the converter and ensure them match up when installing.

6.5.23 Sensor Fact.

The sensor factor is set according to the calibration sheet supplied by the manufacturer. Usually this factor has been set up by the manufacturer before shipping. It is an important value that determines the accuracy of measurement. Do not change it without calibration.

6.5.24 Field Mode

The converter offers three field exciting modes based on the exciting frequency. Mode 1 is the most–commonly used one and suitable for most cases. Mode 2 and 3 are low–frequency exciting modes and are better for large size meter to measure water. The calibration should be taken under the same exciting mode as that used for measurement.

6.5.25 RevMeas.Enbl: Reverse Measurement Enable

If RevMeas.Enbl is set to ON, the converter displays flow and outputs signals when flow direction is reversed. If OFF, the converter displays no flow and does not output signals when reversing.

6.5.26 Multiplying

This item is a multiplying factor selectable from 0.0000 to 3.9999. When calculating the flow rate and total, this factor is taken into account. It is often used to measure the flow in the open channel. If not applied, set the value to 1.0000.

6.5.27 F. Total Set and R. Total Set

Presetting of forward and reverse total counter is designed to start counting from the existing reading when replacing a converter or flowmeter. It provides a continuous total flow read which is convenient for management.

6.5.28 Input Control

This menu item is set to select the function of contact input. There are three options to be chosen from: 'input disabled', 'stop totalizer' and 'reset totalizer'. The converter disables the contact input if 'input disabled' is selected. The contact input is used to start/stop totalizer controlled by ON/OFF switch signal if 'stop totalizer' function is active. If 'reset totalizer' function is enabled, ON (close) contact signal will clear the three internal total flow counters.

6.5.29 Clr Totalizer Enter the 'Totalizer Reset Password' in this menu item and press ENTER to confirm. The converter clears the three internal counter and restart counting if password matched.

6.5.30 Clr Tot. Key

The 'Totalizer Reset Password' is changeable in this menu item if Level-3 password is entered. Remind: keep the new password in a safe place.

6.5.31 Date -y/m/d and Time-h/m/s

These items are used to change the internal real time clock if equipped.

6.5.32 Password L1 ,Password L2 and Password L3

To change the Level-1 to Level-3 passwords, use Level-4 or higher level password to enter and change these two items.

6.5.33 Current Zero and Current Max

Adjust the current output zero point and upper range value. It is not suggested that user make any adjustment since it has been setup to the best condition by the manufacturer.

6.5.34 Meter Factor

This factor is used by the manufacturer to normalize the excitation current and amplifier signal of the converter. DO NOT change it.

6.5.35 Convtr S/N

This serial number records the manufacturing date and code of converter. DO NOT change it.

6.5.36 Sys Reset

This item is reserved for the manufacturer to re-initialize the converter. After system resetting, all settings are set to default values automatically.

7.INSTALLATION

The installation of flowmeter is shown as Fig. 8.

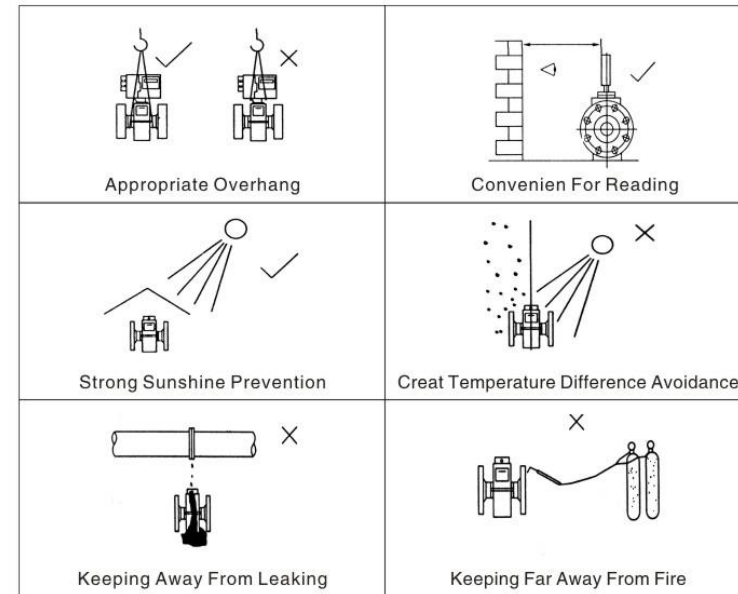

The correct installation flowmeter

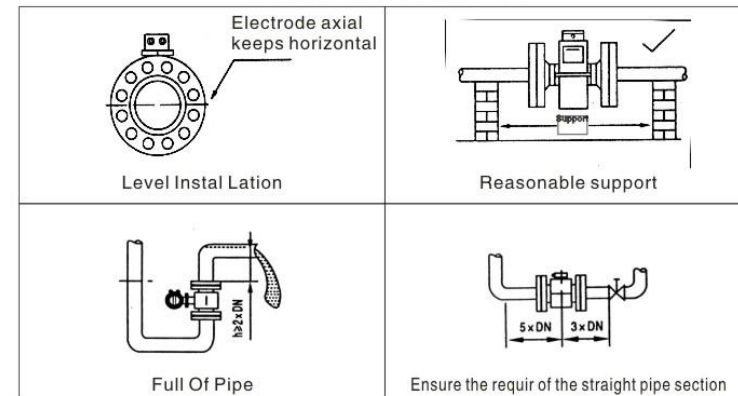

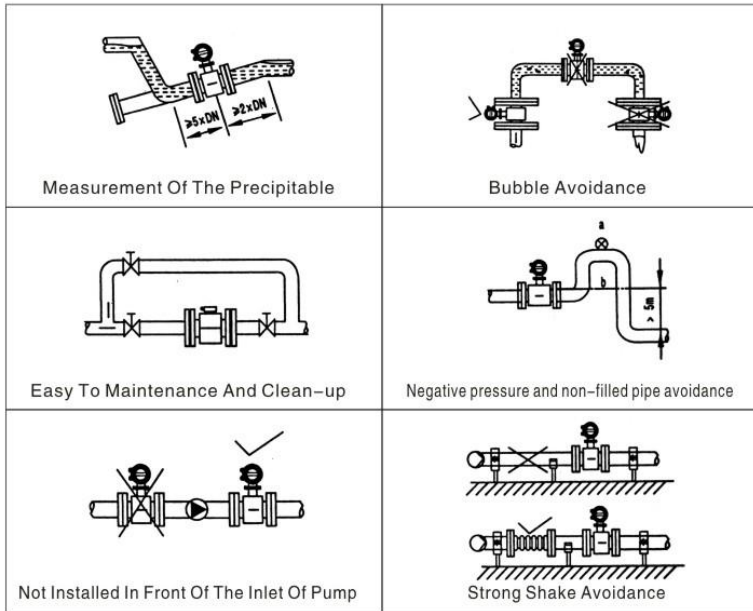

8. WIRING

8.1 GROUDING

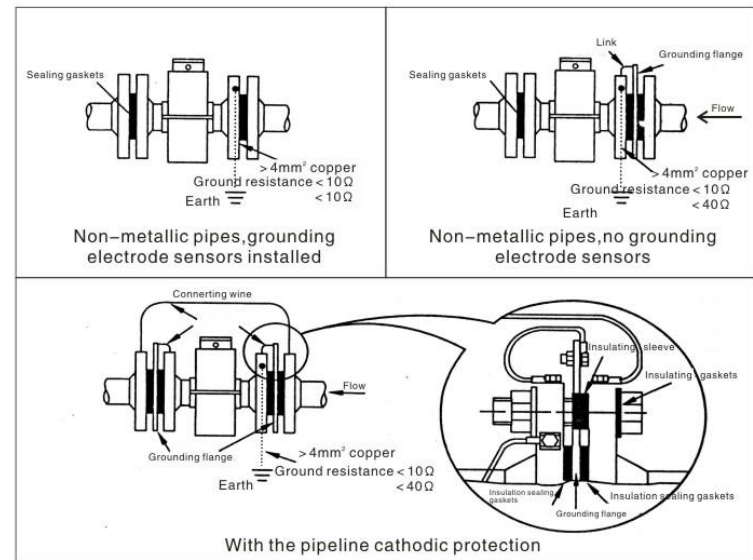
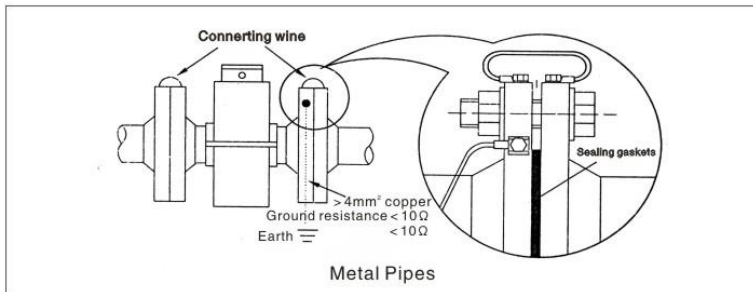

Fig. 9 Grounding of Flowmeter and Pipe

8.2 Converter Terminals and Definition

Terminal blocks and marks are shown in Fig. 10 and Fig. 11

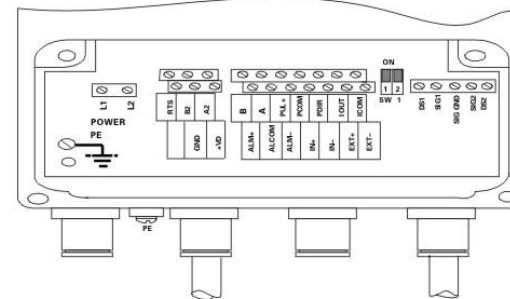

Fig. 10 Remote Type: Terminals and Marks

The definition of terminals and their marks for remote type converter is given as below:

DS1	Shield drive 1
SIG1	Signal input 1
SIG GND	Signal Ground
SIG2	Signal input 2
DS2	Shield drive 2
EXT+	Coil excitation +
EXT-	Coil excitation -
IOUT	Current output +
ICOM	Current output -
PUL+	Frequency/pulse output +
PCOM	Frequency/pulse output -
PDIR	Flow direction indicator +
ALM-	Low alarm output +
ALM+	High alarm output +
ALCOM	Alarm output -
A	RS485 communication A
B	RS485 communication B
IN+	Input contact +
IN-	Input contact -
L1(+)	220V(24V +) input
L2(-)	220V(24V -) input

The dip switch SW1 is set to ON to supply +12V power to pulse output. If external power is used, turn the switch to OFF.

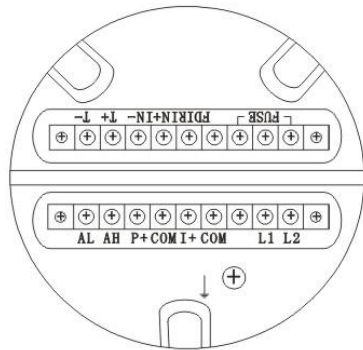

Fig. 11 Compact Type: Terminals and Marks

The definition of terminals and their marks for compact type converter is given as below:

T -	RS485-B
T+	RS485-A
COM	Alarm/flow direction/ pulse output -
FDIR	Flow direction indicator +
AL	Low alarm output +
AH	High alarm output +
IN-	Input contact -
IN+	Input contact +
P+	Frequency/pulse output +
COM	Current/pulse output -
I+	Current output +
L1(+)	220V(24V +) input
L2(-)	220V(24V -) input

8.3 Remote-type Wiring

8.3.1 Terminal Block in Sensor

Fig. 11 Marks of Terminal Block

SIG1: Signal 1 (Connecting to white coax wire of STT3200 cable)

SIG2: Signal 2 (Connecting to black coax wire of STT3200 cable)

DS1: Signal 1 shield drive (Connecting to inner shield layer of white coax wire of STT3200 cable)

DS2: Signal 2 shield drive (Connecting to inner shield layer of black coax wire of STT3200 cable)

SIG GND: Signal ground (Connecting to Ex-shield of STT3200 cable)

EXT+: Coil 1 (Connecting to red cable)

EXT-: Coil 2 (Connecting to yellow cable)

8.3.2 Connection of STT3200 Cable

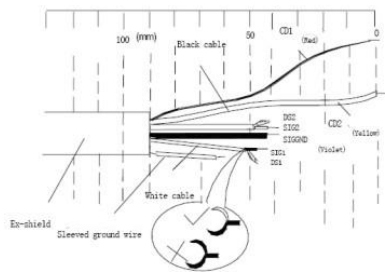

STT3200 Schematic Diagram for Cable Preparation

Fig. 12 Schematic Diagram for STT3200 Cable Preparation

8.4 Output Signal Wiring

The dip switch SW1 is set to ON to supply +12V power to pulse output. A 1KΩ resistor is connected to the +12V power to provide a pull-up. If external power is used, turn the switch to OFF.

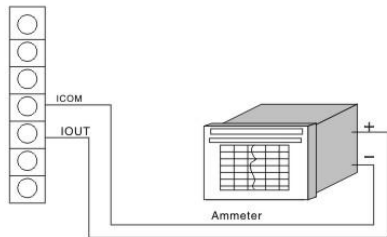

Fig. 13(a) Wiring of current output

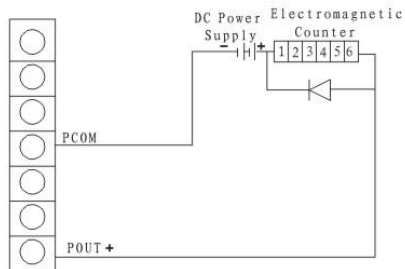

Fig. 13 (b) Example of electromagnetic counter connection

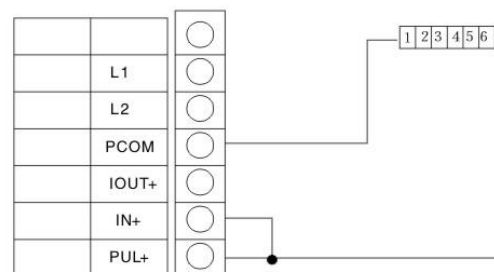

Fig. 13(c) Example of electrical counter connection

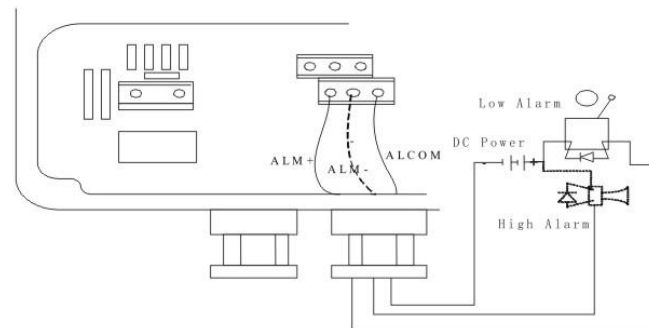

Fig. 13(d) Digital Output Direct Connection

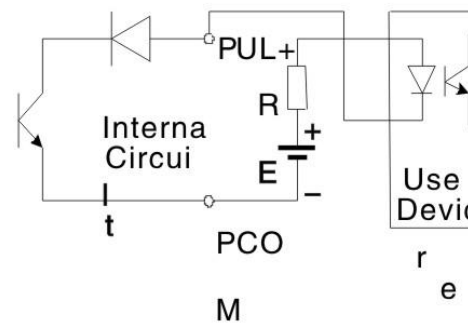

Fig. 13(e) Connection with photo-coupler (e.g. PLC)

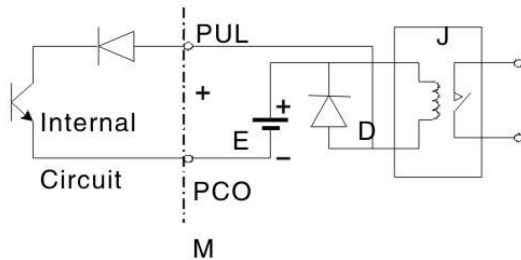

Fig.13 (f) Connection with relay (e.g. PLC)

Generally, the intermediate relay needs 12V or 24V power supply E. D is a surge-absorbing diode, which is usually embedded in the relay. If not, an external one is necessary.

9. Self-diagnostic and Troubleshooting

The converter is made by surface mount technology and is not repairable for user. Do not open the converter case.

The self-diagnosis function of the converter is capable of displaying alarm information except power supply or hardware failures. A '!' symbol is displayed on the right corner of LCD top-line and malfunction information can be read from the bottom-line by pressing DOWN key. User may check the flowmeter according to the alarm information. Some examples of alarms are given below:

- Coil Alm**
- Elctrd Alm**
- EpPipe Alm**
- Low Alarm**
- High Alarm**

Troubleshooting information is given below:

9.1 No display

- Check the connection of power supply;
- Check fuse;
- Check the voltage of power supply;
- Check if the LCD contrast can be adjusted. Adjust it if possible;
- Return to base, if a) to d) are OK.

9.2 Coil Alarm

- a) Check if terminal EXT+ and EXT- are open;
- b) Check if coil resistance is less than 150Ω;
- c) Replace converter if a) and b) are OK.

9.3 Empty Pipe Alarm and Electrodes Alarm

- a) Check if the sensor pipe is filled with fluid;
- b) Check the connection of signal wiring;
- c) Connect the terminal SIG1, SIG2 and SIG GND. If the alarm display disappears, it is confirmed the converter is normal. The alarm may be caused by the bubble in the fluid;
- D) For electrodes alarm, measure the resistance between two electrodes with a multimeter. The read should be between 3 to 50kΩ. Otherwise, the electrodes are contaminated or covered.

9.4 High Alarm

Increase the flow range.

9.5 Low Alarm

Reduce the flow range.

9.6 Inaccurate Measurement

- a) Check if the sensor pipe is filled with the fluid to be measured.
- b) Check the wiring;
- c) Check if the sensor factor and flow zero are the same as those on the calibration sheet.

10. PACKAGING

The package includes:

- The electromagnetic flowmeter ordered;
- Instruction Manual;

11. TRANSPORTATION AND STORAGE

To prevent the flowmeter from damage in the transportation, the package should be kept in unopened status before reaching installation site. The storage room should be satisfied with the following conditions:

- a. Rain-proof, humidity-proof;
- b. Strong Vibration and Shake Avoidance
- c. Temperature between -20 to +60°C, relative humidity less than 80%

12. OPERATION

Before operation, the following inspection should be done to check if:

- a. There is any damage caused by transportation or installation;
- b. The power used is same as the label on the flowmeter;
- c. The wiring is correct.

After inspection, turn the valve on to fill the pipe up and make sure there is no leakage and the gas inside the pipe is eliminated. Switch on the power supply and the flowmeter is ready to use after 10 minutes warm-up.

If there is any problem, please refer to the Section 9 for troubleshooting. If still not working properly, contact the manufacturer immediately.